

BEDLINER / TAILGATE-COVER INSTALLATION INSTRUCTIONS

INSTRUCCIONES DE INSTALACIÓN DE BEDLINER Y CUBIERTA PARA COMPUERTA

INSTRUCTIONS D'INSTALLATION POUR COUVERTURE DE BOÎTE ET DE HAYON

Installation Preparation / Preparación para la instalación / Préparation pour installation

PLEASE READ ENTIRE INSTALLATION INSTRUCTION SHEET BEFORE BEGINNING INSTALLATION. Improper installation may void warranty. NOTE: Bedliner can be installed by one person. However, using two people is recommended by the manufacturer.

SÍRVASE LEER TODA LA HOJA DE INSTRUCCIONES DE INSTALACIÓN ANTES DE COMENZAR. La instalación indebida puede invalidar la garantía. NOTA: El forro puede ser instalado por una sola persona. Sin embargo, el fabricante recomienda que lo hagan dos personas.

VEUILLEZ LIRE COMPLÈTEMENT LE FEUILLET D'INSTRUCTIONS D'INSTALLATION AVANT DE COMMENCER L'INSTALLATION. Une installation incorrecte peut annuler la garantie. NOTE: La doublure peut être installée par une seule personne. Cependant, le fabricant recommande qu'elle le soit par deux.

WARNING: Do not transport a pick up truck facing backward with a liner installed. Air can get under the liner which may result in the liner coming out of the truck and causing damage or injury.

ADVERTENCIA: No transporte una camioneta apuntando hacia atrás con la cubierta instalada. Se puede meter aire debajo de la misma, lo cual puede hacer que esta se despegue y ocasione un accidente.

AVERTISSEMENT : Ne transportez pas, dans le sens contraire de la marche, un camion équipé d'une doublure de caisse. De l'air peut pénétrer sous la doublure qui risque alors de se détacher et de causer des dommages ou des blessures.

Kit Components / Components del Kit / Les éléments du kit

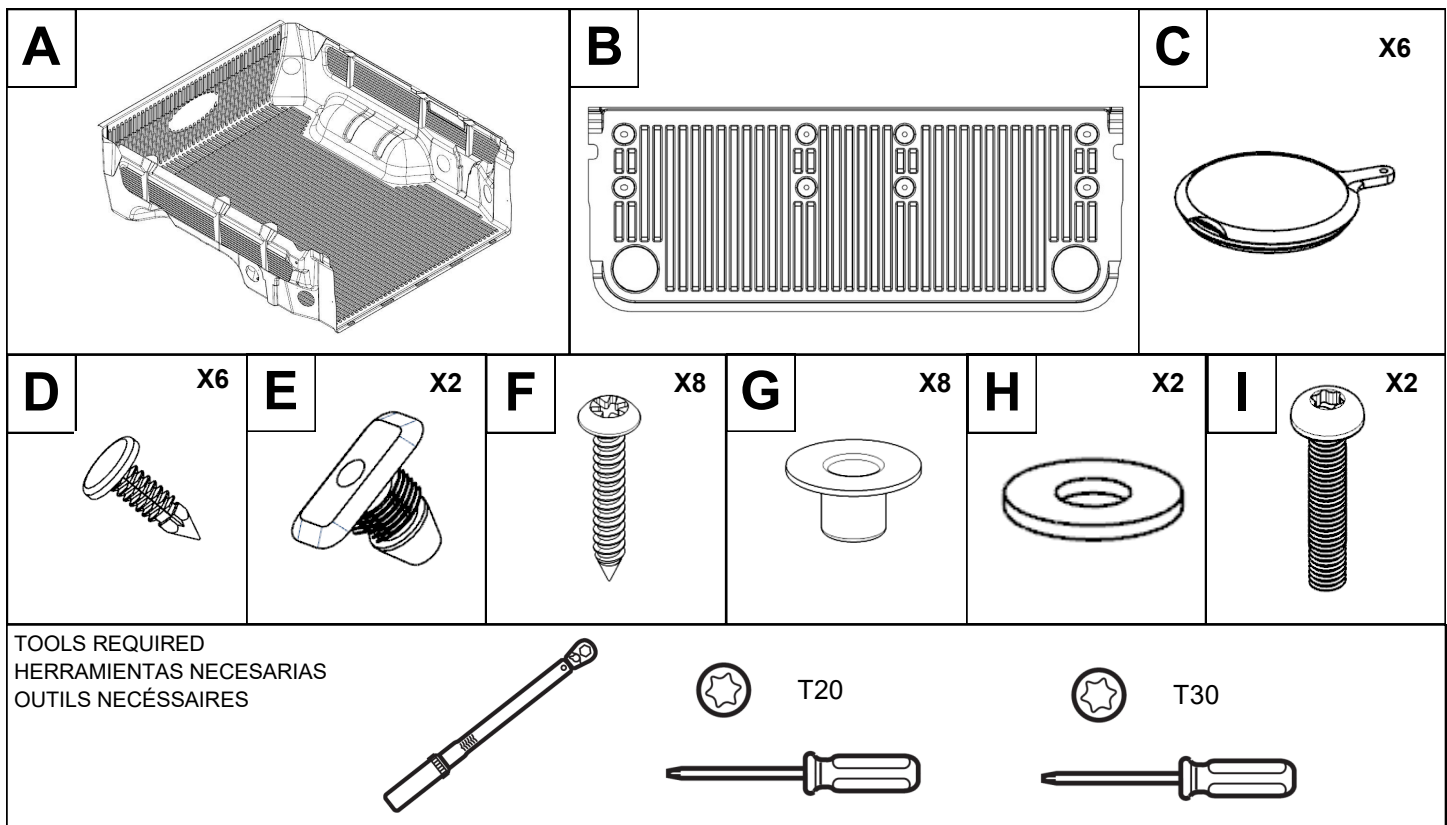

Manufactured by:

PENDA CORPORATION • P.O. Box 449, 2344 W. Wisconsin St., Portage, WI 53901-0449
(800) 356-7704 • (800) 362-7611 (In Wisconsin) • (Internet) www.penda.com

1

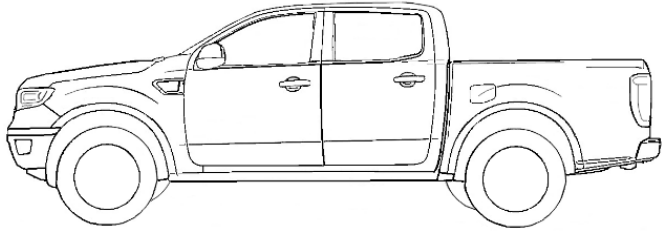

NOTE: Clean and wash the truck bed thoroughly.
 NOTA: Limpie y lave completamente la caja del camion.
 NOTE: Nettoyer et laver soigneusement la benne de la camionnette.

2

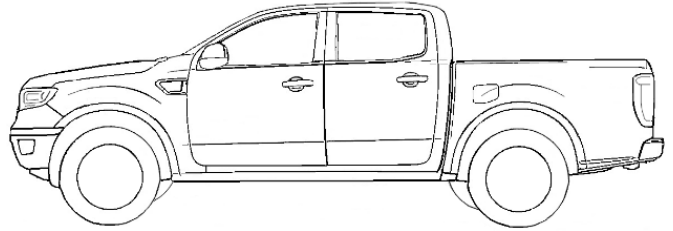
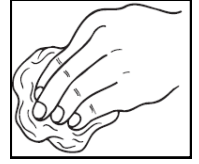

NOTE: Dry truck bed completely.
 NOTA: Seque completamente la caja del camión.
 NOTE: Sécher complètement la benne de la camionnette.

3

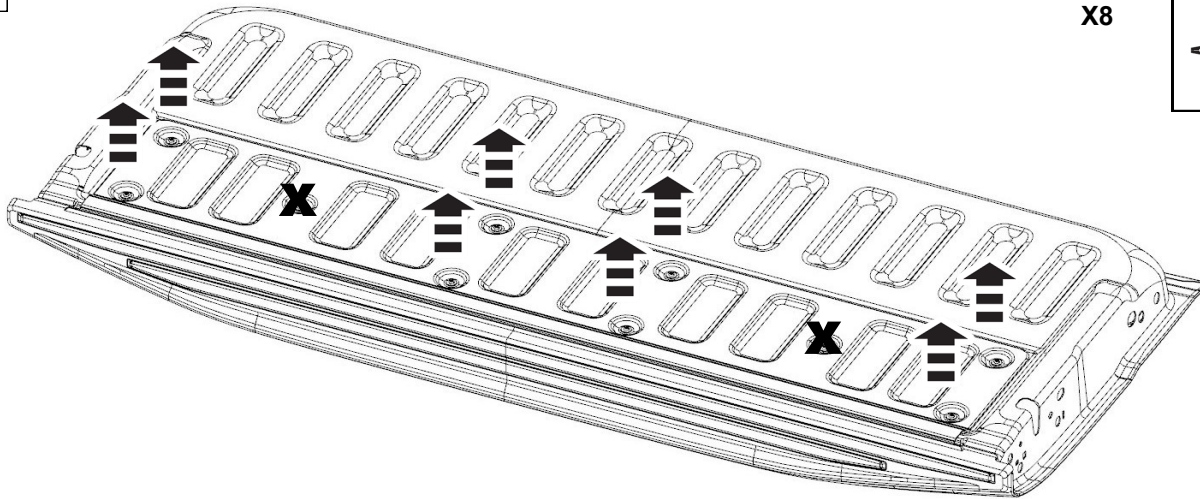

X8

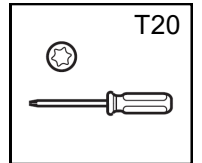

T20

4

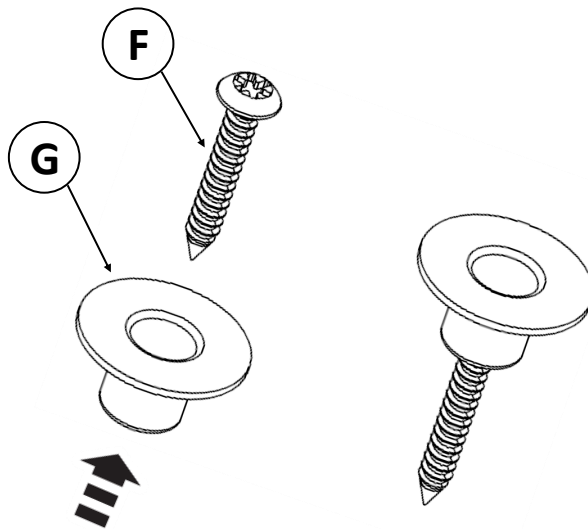

Manufactured by:

PENDA CORPORATION • P.O. Box 449, 2344 W. Wisconsin St., Portage, WI 53901-0449
(800) 356-7704 • (800) 362-7611 (In Wisconsin) • (Internet) www.penda.com

5

B

T20

X4

NOTE: Loose fit and center tailgate liner.
 NOTA: Presente la cubierta sobre la tapa y céntrala.
 NOTE: Pas trop serré en place et au centre du panneau de hayon.

6

B

T20

X4

NOTE: Loose fit and center tailgate liner.
 NOTA: Presente la cubierta sobre la tapa y céntrala.
 NOTE: Pas trop serré en place et au centre du panneau de hayon.

7

B

2.5 Nm

NOTE: Torque to 1.8 lb.-ft. Follow tightening sequence above.
 NOTA: Apriete a un torque de 2.5 N-m. Siga la secuencia de arriba para apretar la pieza.
 NOTE: Serrer a un couple de 2.5 N-m. Suivre l'ordre de serrage ci-dessus.

8

A

9

10

Manufactured by:
PENDA CORPORATION • P.O. Box 449, 2344 W. Wisconsin St., Portage, WI 53901-0449
(800) 356-7704 • (800) 362-7611 (In Wisconsin) • (Internet) www.penda.com

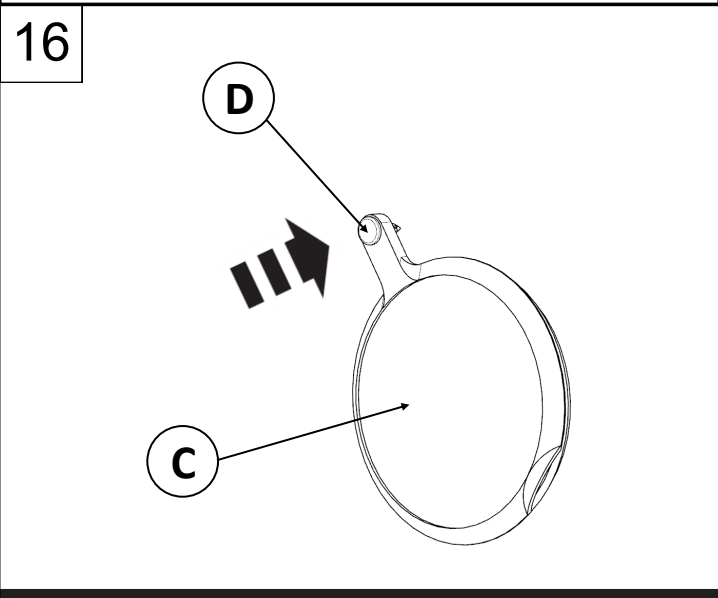
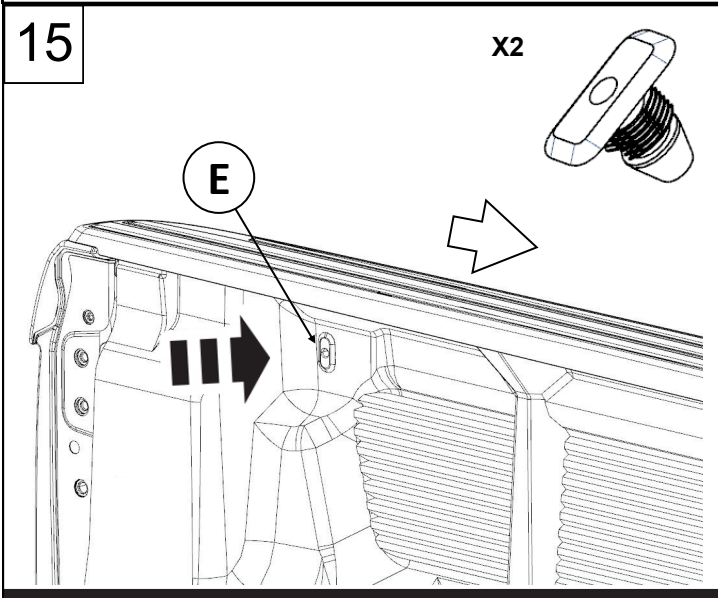
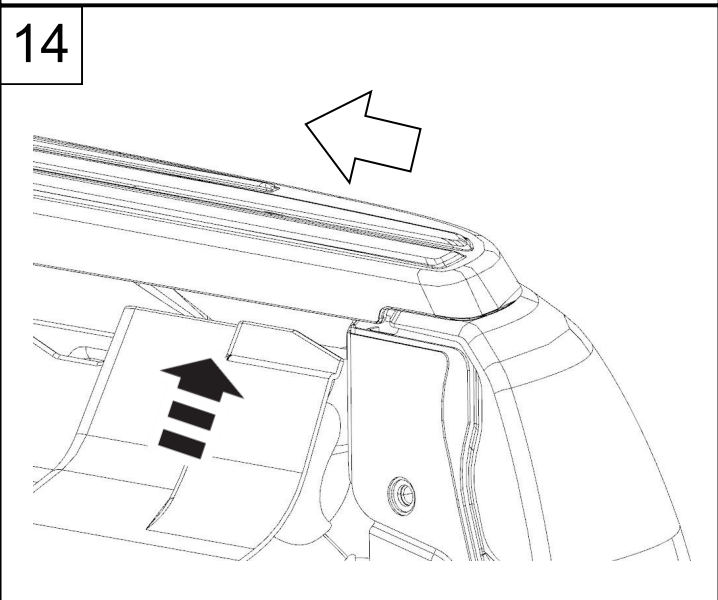
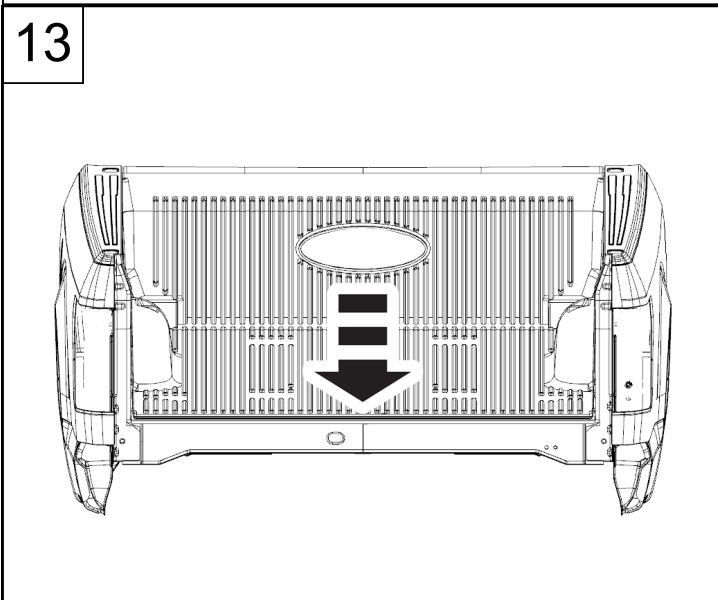
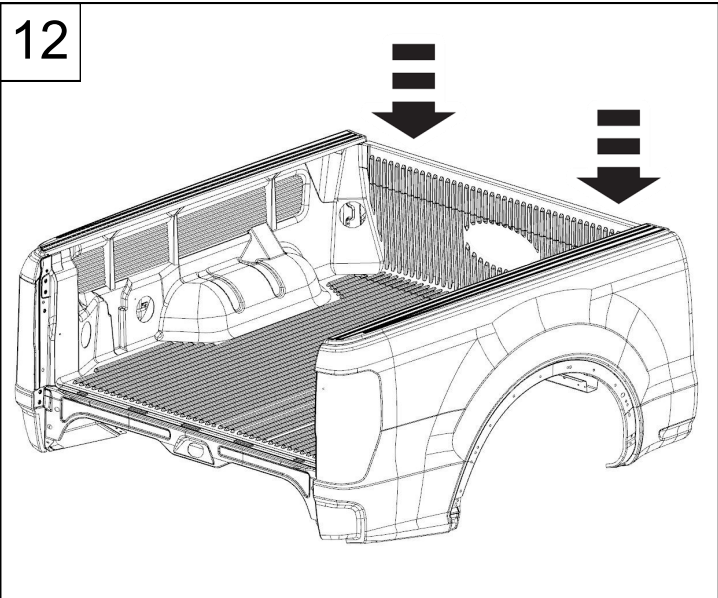
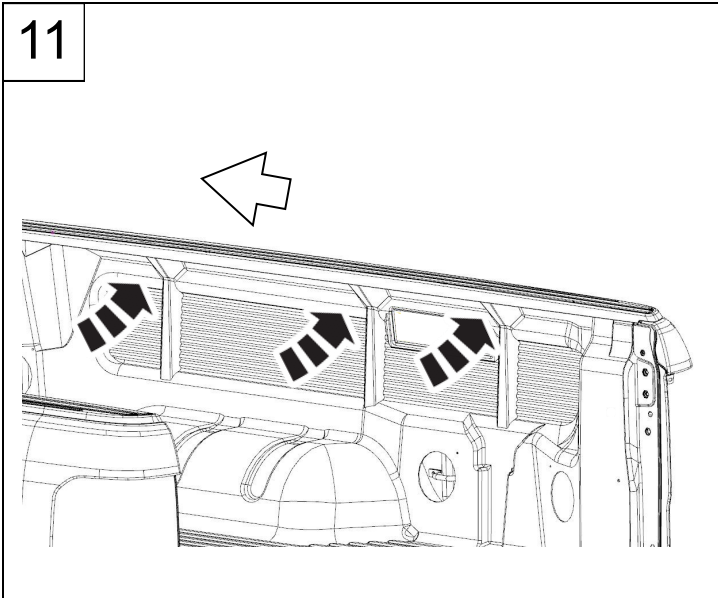

Manufactured by:
PENDA CORPORATION • P.O. Box 449, 2344 W. Wisconsin St., Portage, WI 53901-0449
(800) 356-7704 • (800) 362-7611 (In Wisconsin) • (Internet) www.penda.com

17

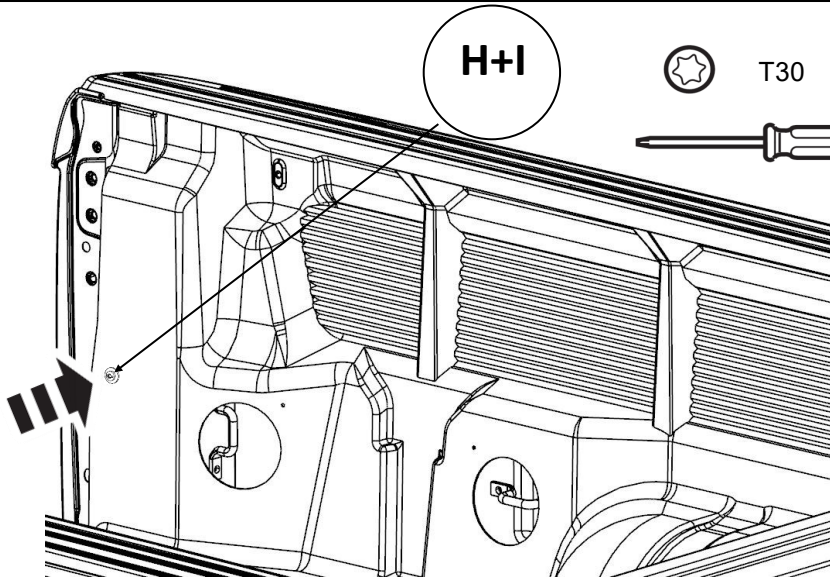

T30

X2



16 Nm



X2



NOTE: Torque to 11.8 lb.-ft.

NOTA: Apriete a un torque de 16 N-m.

NOTE: Serrer a un couple de 16 N-m.

18

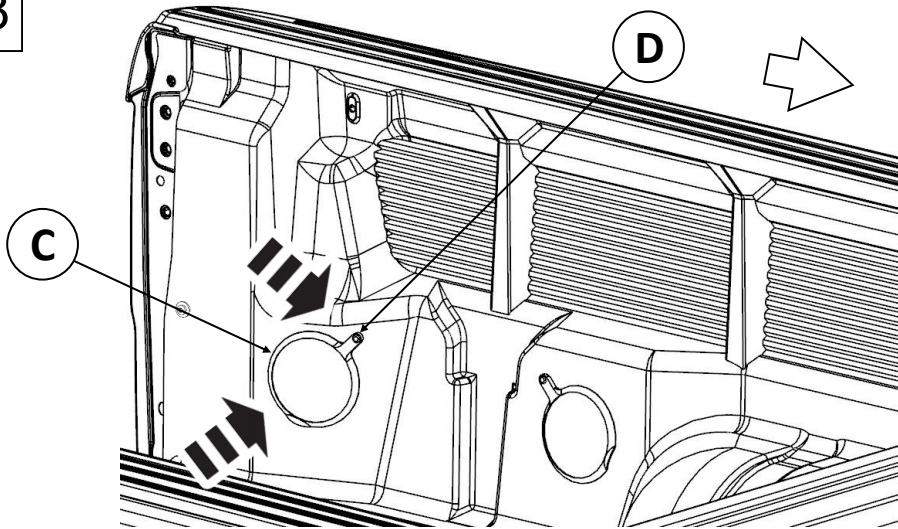

X6



Manufactured by:

PENDA CORPORATION • P.O. Box 449, 2344 W. Wisconsin St., Portage, WI 53901-0449
(800) 356-7704 • (800) 362-7611 (In Wisconsin) • (Internet) www.penda.com