

# FORD TRANSIT VAN PANELS (2015+)

## WHEEL WELL COVER

### INSTALLATION INSTRUCTIONS

#### BEFORE INSTALLATION

**NOTE:** When assembling with a Penda VanGuard floor and wall panels, the floor panels should be installed first, followed by the wheel well covers over the floor panels, then the wall panels over the floor panels and wheel well covers.

#### INSTALLING INSULATION PADS ON WHEEL COVERS

1. Center insulation pads on the inside (smooth side) of the wheel cover and aligning the bottom of the pad with the crease in the wheel cover (see Figure 1).
2. Peel off the bottom section of adhesive and stick to wheel cover (see Figure 2).
3. Peel off one of the sections of adhesive on the flaps, press the flap flush against the curvature of the cover and press the adhesive tight. Repeat this with the other two flaps of the pad.
4. Repeat steps 1-3 with the other wheel cover.

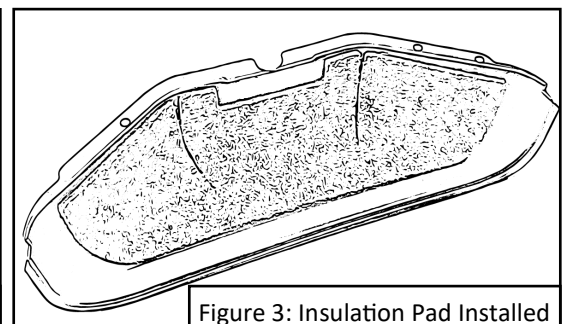
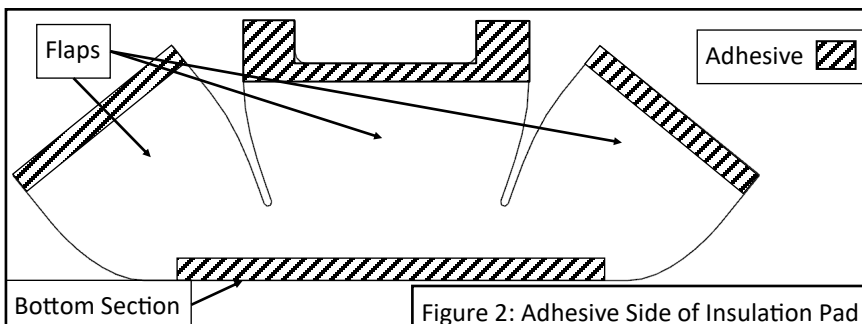
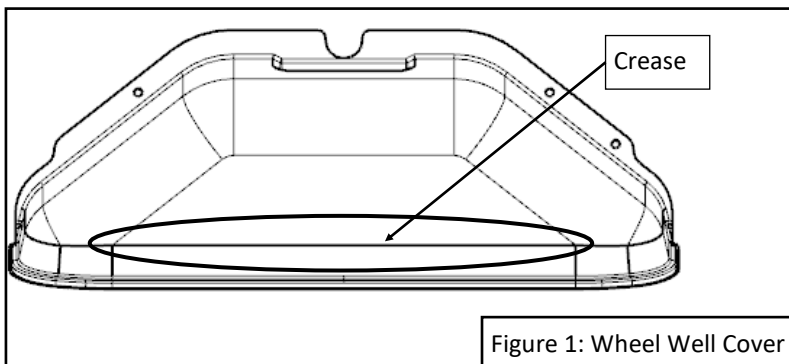

## INSTALLING WHEEL COVERS WITHOUT VANGUARD WALL PANELS

1. Place cover on interior wheel well.
2. Push (3) trim pins into the three holes on the wheel cover (see Figure 4).
3. Repeat steps 1 and 2 with the other wheel well.

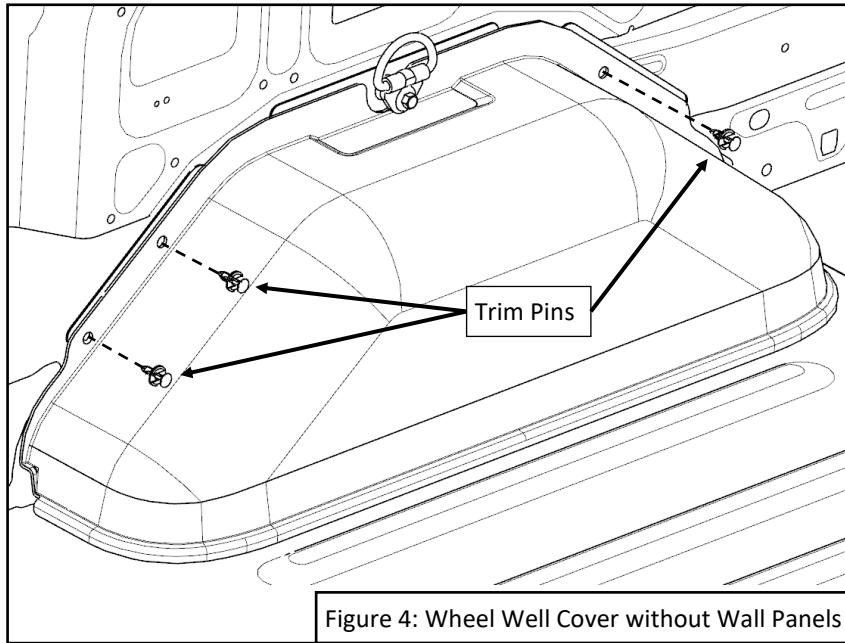

## INSTALLING WHEEL COVERS WITH VANGUARD WALL PANELS

1. Place wheel covers on both interior wheel wells. Do not install trim pins.
2. Install wall panels according to the wall panel installation instructions.
3. On the driver's side make sure that the push pin goes through both the wall and the wheel cover (see Figure 5).

